

Rev No.	Description	Date	Name
B	LTRN36 layout	22/10/09	

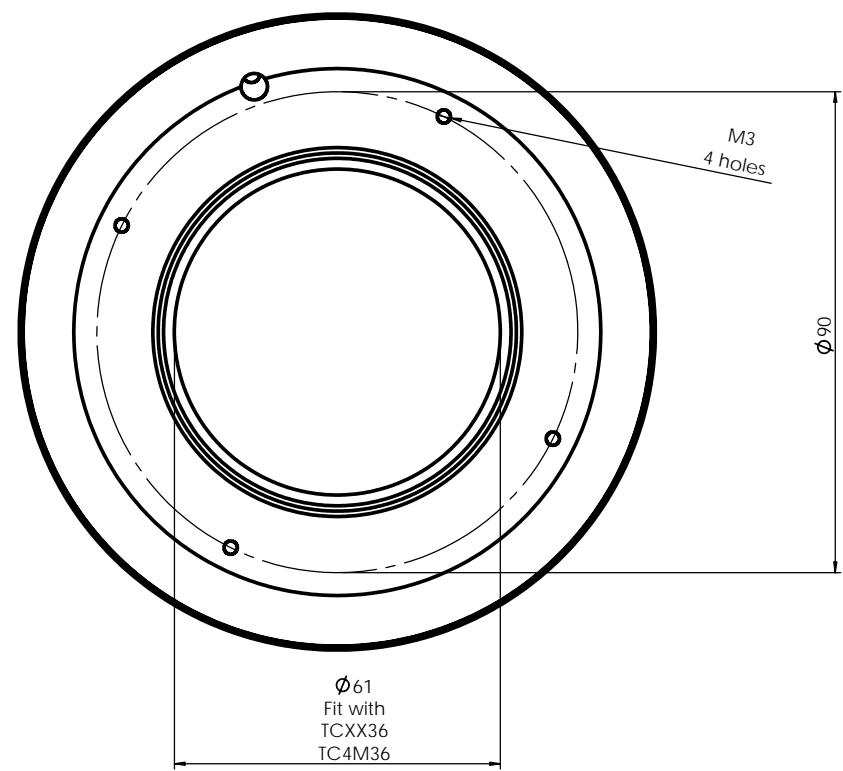
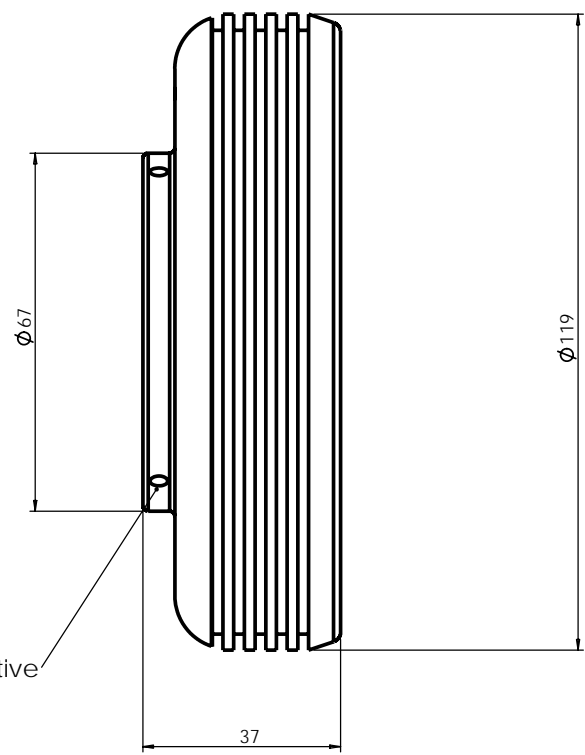

M4  
3 holes  
to fix objective

Material	N.A.		Mass	360 gr.	Scale	1:1	
Surface treatment	N.A.		Project-Prod Item/Instrument LTRN36				
Geometrical tolerance (ISO 2768-2)		Class	K	Undimensioned bevels	1x45°	Description LTRN36 layout	
Linear tolerance (ISO 2768-2)		Class	m	Undimensioned radii	R 0.5		
0.5	>3-	>6-	>30-	>120	>400-	>1000	>2000
±0.1	±0.1	±0.2	±0.3	±0.5	±0.8	±1.2	±2
Date		Name		Drawing No.		Sheet	
Designed		22/10/09		18332-0-B		1/1	
Draw		22/10/09		Reproduction forbidden without specific authorization			
Checked		X		www.opto-engineering.com			
OPTO ENGINEERING S.r.l. - 46100 Mantova Italy - Via Cremona, 29/2 - Tel. +39 0376 263565 - e-mai: info@opto-engineering.com - http://www.opto-engineering.com							