

TCBENCH48

0,18x TELECENTRIC OPTICAL BENCH KIT



WWW.OPTO-ENGINEERING.COM

LT CL illuminator:
LTCL48/G

Teleclamp:
CMHO48

Bi-Telecentric Lnes:
TC2348

Pattern Holder:
CMPH036-056

Base Plate
CMPT48

Pattern:
PT036-056

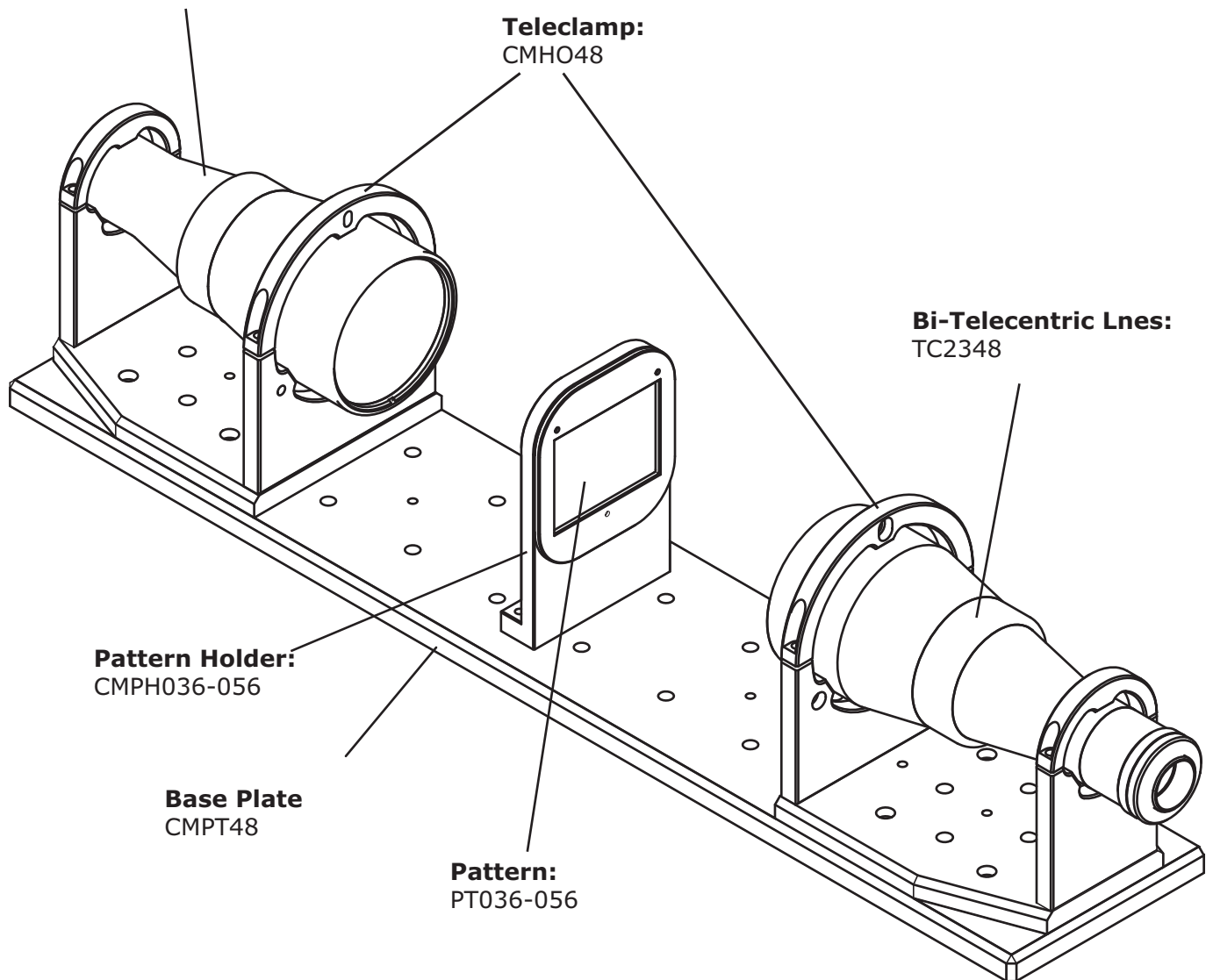

Part Number	TCBENCH48	
Magnification		0,184
Field Of View	(mm x mm)	
with 1/2" (6,4 x 4,8) detector		34,8 x 26,1
with 1/1.8" (7,13 x 5,37) detector		38,8 x 29,2
with 2/3" (8,8 x 6,6) detector		47,9 x 35,9
Measurement Accuracy	(micron)	31,0
Measurement Accuracy	(%)	0,06%
Field Depth	(mm)	24,00
CTF @70 lp/mm	(%)	> 50
Mount		C
Length	(mm)	636,0
Width	(mm)	117,0
Height	(mm)	147,5
Weight	(g)	5600

MECHANICAL DRAWINGS: see next page >>