

# TCBENCH96

## 0,09x TELECENTRIC OPTICAL BENCH KIT

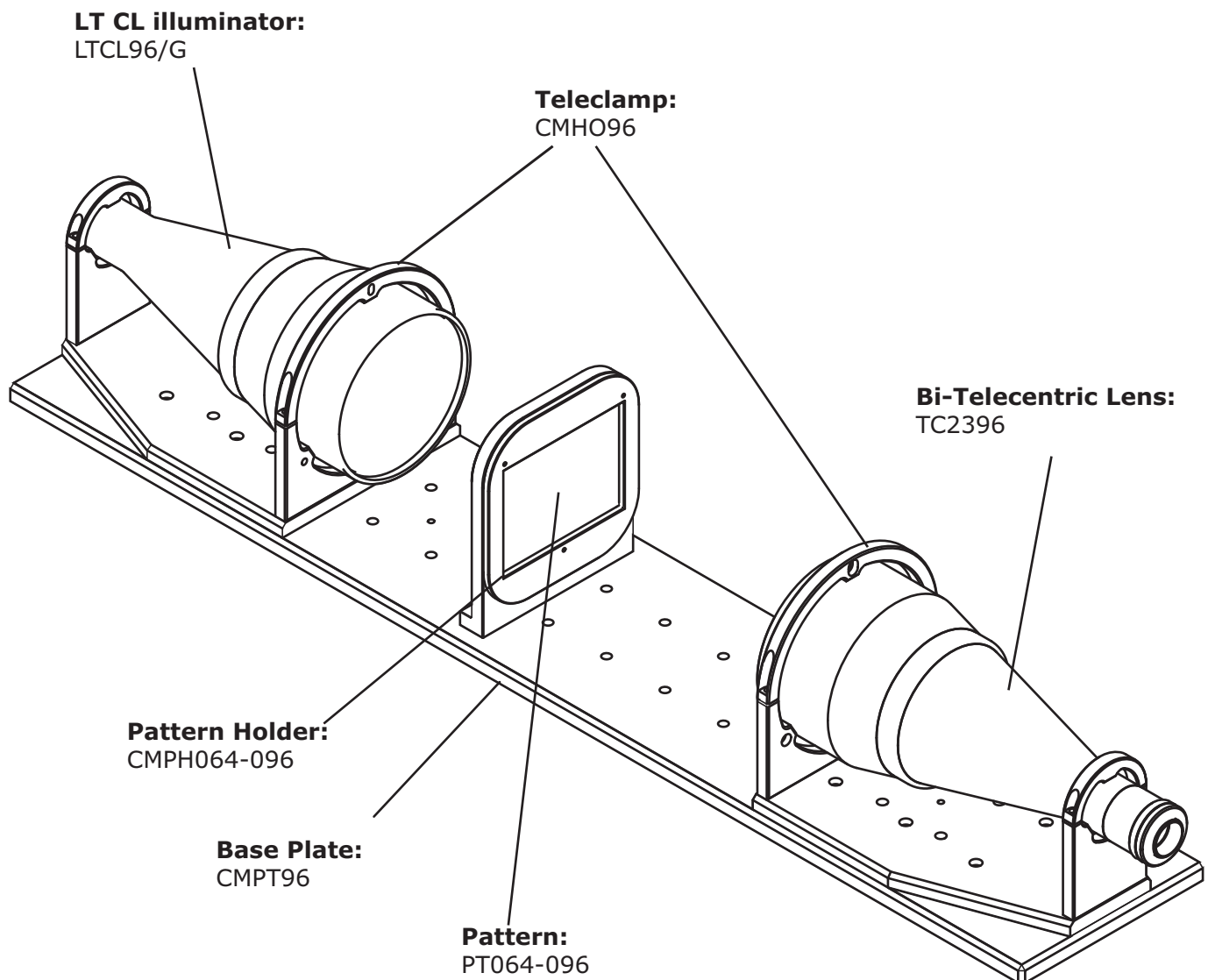

WWW.OPTO-ENGINEERING.COM



<b>Part Number</b>		<b>TCBENCH96</b>
<b>Magnification</b>		0,093
<b>Field Of View</b>	<b>(mm x mm)</b>	
with 1/2" (6,4 x 4,8) detector		68,5 x 51,4
with 1/1.8" (7,13 x 5,37) detector		76,3 x 57,5
with 2/3" (8,8 x 6,6) detector		94,2 = 70,7
<b>Measurement Accuracy</b>	<b>(micron)</b>	70,0
<b>Measurement Accuracy</b>	<b>(%)</b>	0,07%
<b>Field Depth</b>	<b>(mm)</b>	94,00
<b>CTF @70 lp/mm</b>	<b>(%)</b>	> 50
<b>Mount</b>		C
<b>Length</b>	<b>(mm)</b>	1053,0
<b>Width</b>	<b>(mm)</b>	206,5
<b>Height</b>	<b>(mm)</b>	185,0
<b>Weight</b>	<b>(g)</b>	15300

**MECHANICAL DRAWINGS: see next page >>**